

Ontwerp: David Vanhee

VRAGEN?

[www.littlebrickroom.be](http://www.littlebrickroom.be)  
[dvanhee@hotmail.com](mailto:dvanhee@hotmail.com)

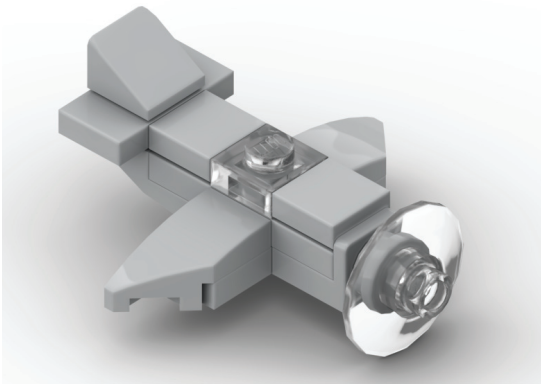

<input type="checkbox"/>		Bracket 1 x 1 - 1 x 1 Inverted 36840 Light Bluish Gray	New	-	Want: 1 Have: -
<input type="checkbox"/>		Plate 1 x 3 3623 Light Bluish Gray	New	-	Want: 2 Have: -
<input type="checkbox"/>		Plate, Modified 1 x 2 with 1 Stud with Groove and Bottom Stud Holder (Jumper) 15573 Light Bluish Gray	New	-	Want: 1 Have: -
<input type="checkbox"/>		Plate, Round 1 x 1 4073 Light Bluish Gray	New	-	Want: 1 Have: -
<input type="checkbox"/>		Slope 30 1 x 1 x 2/3 54200 Light Bluish Gray	New	-	Want: 1 Have: -
<input type="checkbox"/>		Slope, Curved 2 x 1 x 2/3 Inverted 24201 Light Bluish Gray	New	-	Want: 1 Have: -

<input type="checkbox"/>		Tile 1 x 1 with Groove 3070b Light Bluish Gray	New	-	Want: 1 Have: -
<input type="checkbox"/>		Wedge 2 x 1 x 2/3 Left 29120 Light Bluish Gray	New	-	Want: 1 Have: -
<input type="checkbox"/>		Wedge 2 x 1 x 2/3 Right 29119 Light Bluish Gray	New	-	Want: 1 Have: -
<input type="checkbox"/>		Dish 2 x 2 Inverted (Radar) 4740 Trans-Clear	New	-	Want: 1 Have: -
<input type="checkbox"/>		Plate 1 x 1 3024 Trans-Clear	New	-	Want: 1 Have: -

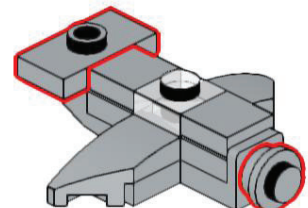
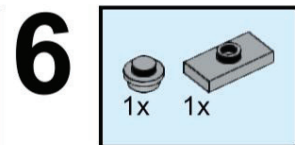
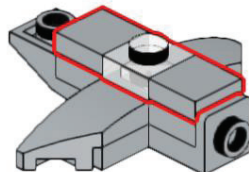
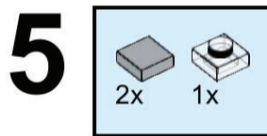
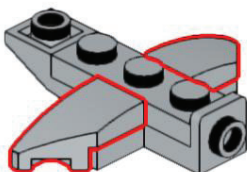
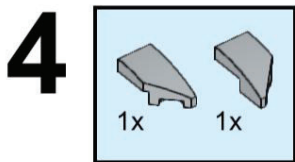
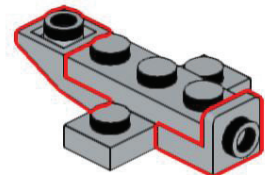
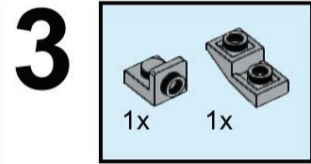
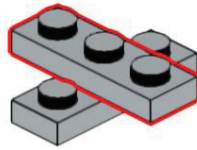
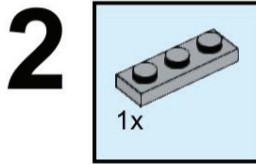
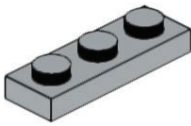
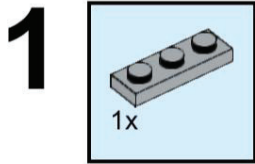

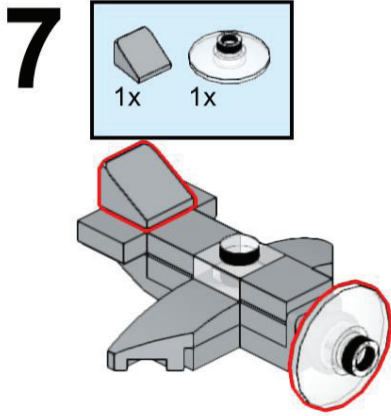

De Focke-Wulf Fw 190 was een eenmotorig jachtvliegtuig dat door de Duitse Luftwaffe tijdens de Tweede Wereldoorlog werd ingezet. Toen het toestel zijn intrede deed in 1941 kon het met recht het beste toestel ter wereld genoemd worden. De ontwerper was Kurt Tank.

Lengte: 8,97 m (Fw 190a)  
Topsnelheid: 685 km/h  
Bereik: 835 km  
Spanwijdte: 10 m  
Gewicht: 3.490 kg  
Motortype: sternmotor van BMW met ca. 1700 pk



In opdracht van Provinciaal Archeocentrum Velzeke