

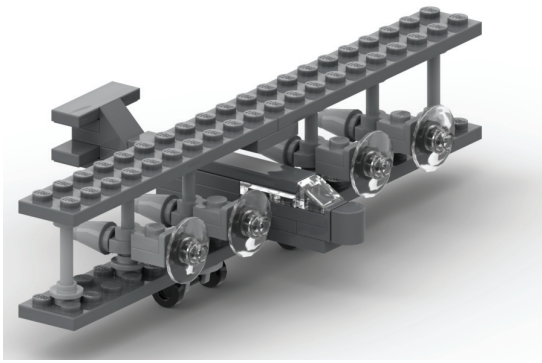

























Ontwerp: David Vanhee

VRAGEN?

www.littlebrickroom.be
dvanhee@hotmail.com



<input type="checkbox"/>		Plate, Round 1 x 1 4073 ■ Black	New	-	Want: 4 Have: -
<input type="checkbox"/>		Wheel Skateboard / Trolley 2496 ■ Black	New	-	Want: 2 Have: -
<input type="checkbox"/>		Bracket 1 x 1 - 1 x 1 Inverted 36840 ■ Dark Bluish Gray	New	-	Want: 1 Have: -
<input type="checkbox"/>		Plate 1 x 1 3024 ■ Dark Bluish Gray	New	-	Want: 3 Have: -
<input type="checkbox"/>		Plate 1 x 2 3023 ■ Dark Bluish Gray	New	-	Want: 2 Have: -
<input type="checkbox"/>		Plate 1 x 3 3623 ■ Dark Bluish Gray	New	-	Want: 1 Have: -
<input type="checkbox"/>		Plate 1 x 4 3710 ■ Dark Bluish Gray	New	-	Want: 1 Have: -
<input type="checkbox"/>		Plate 1 x 6 3666 ■ Dark Bluish Gray	New	-	Want: 1 Have: -
<input type="checkbox"/>		Plate 2 x 10 3832 ■ Dark Bluish Gray	New	-	Want: 4 Have: -
<input type="checkbox"/>		Plate 2 x 2 3022 ■ Dark Bluish Gray	New	-	Want: 1 Have: -
<input type="checkbox"/>		Plate, Modified 1 x 2 with 1 Stud with Groove and Bottom Stud Holder (Jumper) 15573 ■ Dark Bluish Gray	New	-	Want: 2 Have: -
<input type="checkbox"/>		Slope 45 2 x 1 with 2/3 Cutout 92946 ■ Dark Bluish Gray	New	-	Want: 1 Have: -
<input type="checkbox"/>		Slope, Curved 1 x 1 x 2/3 Double 49307 ■ Dark Bluish Gray	New	-	Want: 1 Have: -
<input type="checkbox"/>		Tile 1 x 3 63864 ■ Dark Bluish Gray	New	-	Want: 2 Have: -

<input type="checkbox"/>		Tile 1 x 6 6636 Dark Bluish Gray	New	-	Want: 1 Have: -
<input type="checkbox"/>		Bar 1L with Clip Mechanical Claw - Cut Edges and Hole on Side 48729b Light Bluish Gray	New	-	Want: 4 Have: -
<input type="checkbox"/>		Bar 3L (Bar Arrow) 87994 Light Bluish Gray	New	-	Want: 6 Have: -
<input type="checkbox"/>		Bracket 1 x 1 - 1 x 1 Inverted 36840 Light Bluish Gray	New	-	Want: 4 Have: -
<input type="checkbox"/>		Cone 1 x 1 with Top Groove 4589b Light Bluish Gray	New	-	Want: 4 Have: -
<input type="checkbox"/>		Plate 1 x 1 3024 Light Bluish Gray	New	-	Want: 4 Have: -
<input type="checkbox"/>		Plate, Modified 1 x 1 with Open O Clip Thick (Vertical Grip) 4085d Light Bluish Gray	New	-	Want: 4 Have: -
<input type="checkbox"/>		Plate, Round 1 x 1 with Open Stud 85861 Light Bluish Gray	New	-	Want: 12 Have: -
<input type="checkbox"/>		Plate, Round 2 x 2 Thin with Wheel Holder 2655 Light Bluish Gray	New	-	Want: 2 Have: -
<input type="checkbox"/>		Dish 2 x 2 Inverted (Radar) 4740 Trans-Clear	New	-	Want: 4 Have: -
<input type="checkbox"/>		Plate 1 x 2 3023 Trans-Clear	New	-	Want: 1 Have: -

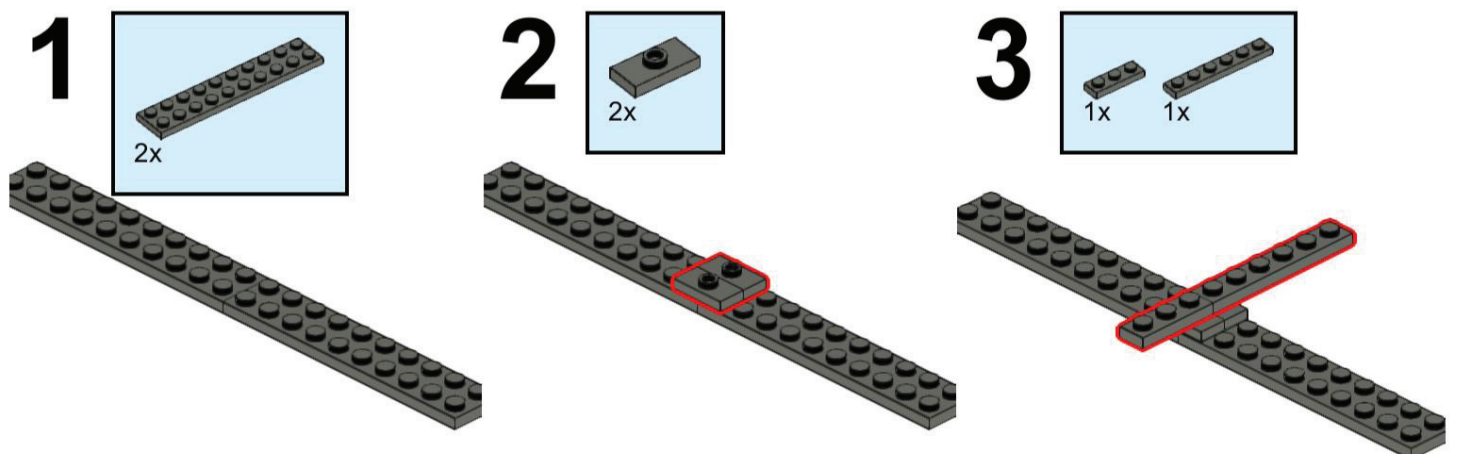

4

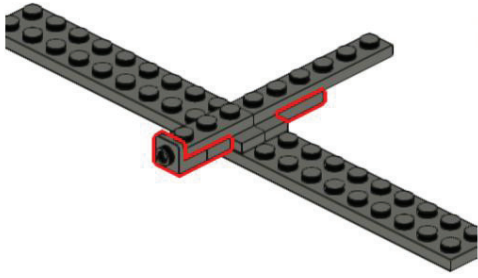
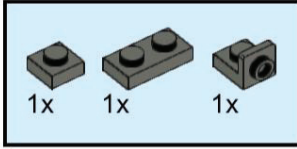

5

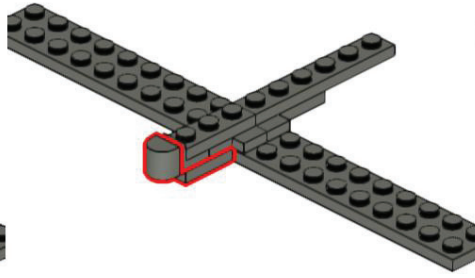
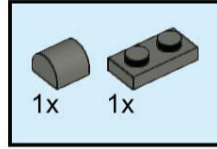

6

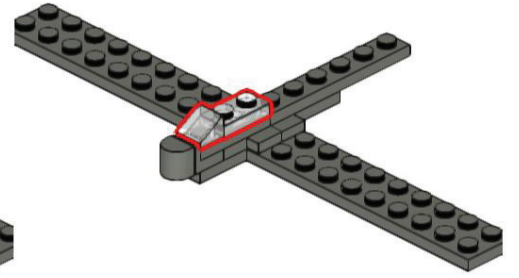
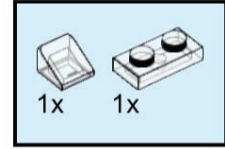

7

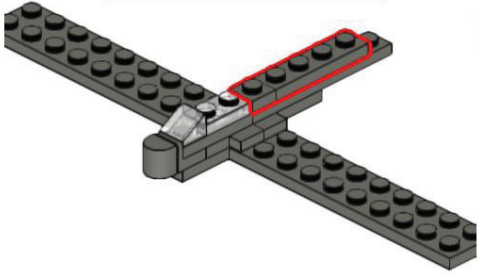
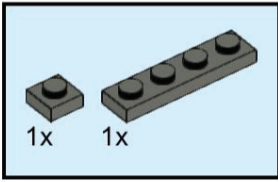

8

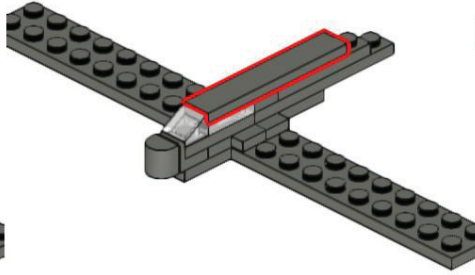
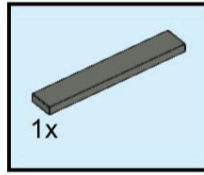

9

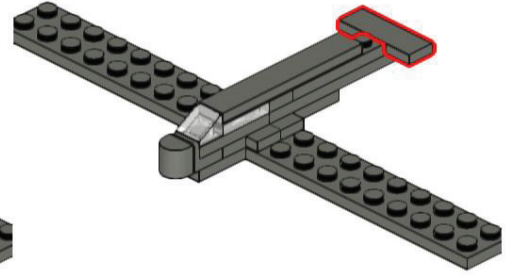
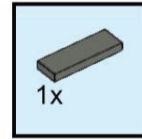

10

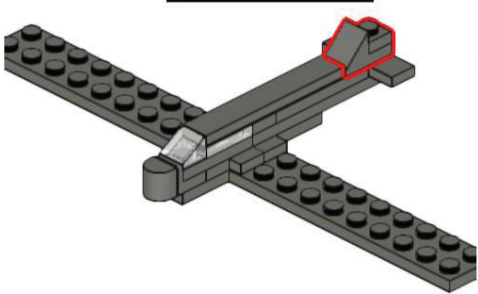
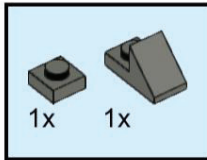

11

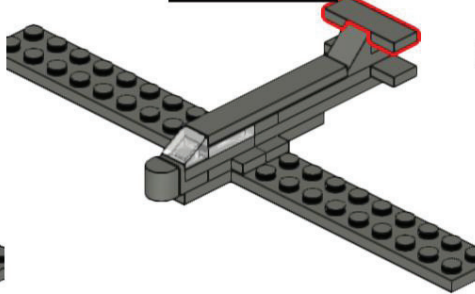
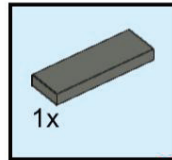

12

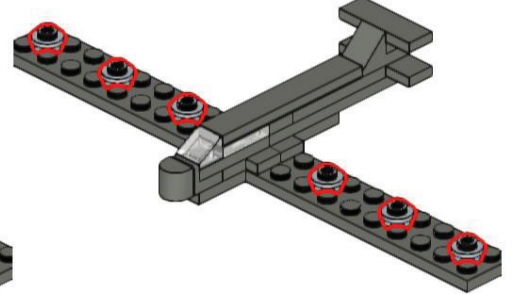

13

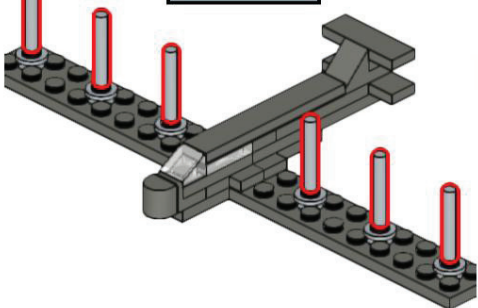
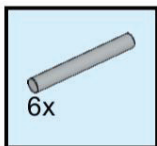

14

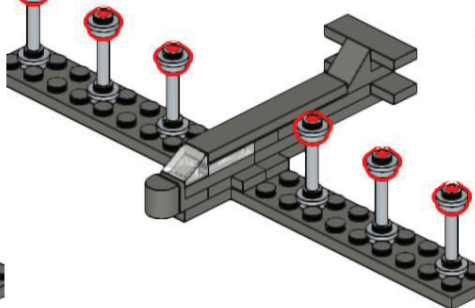

15

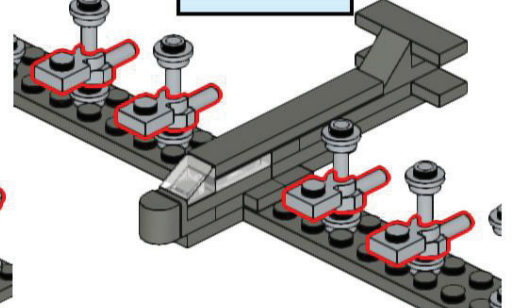
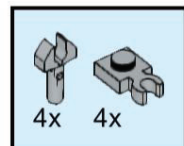

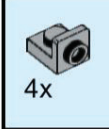
16  4x

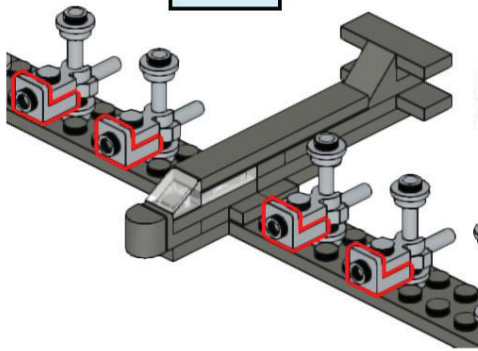

17  4x

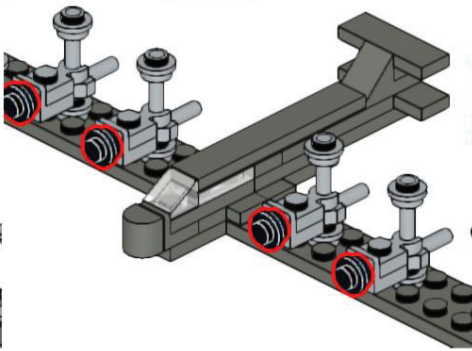

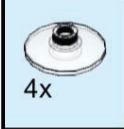
18  4x

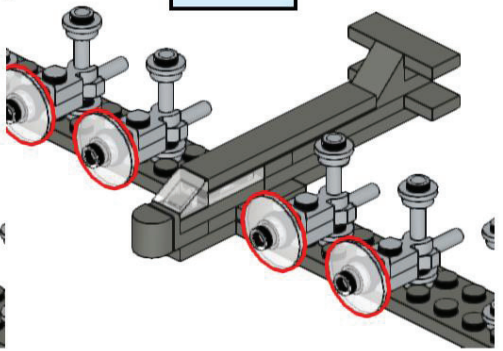

19  4x

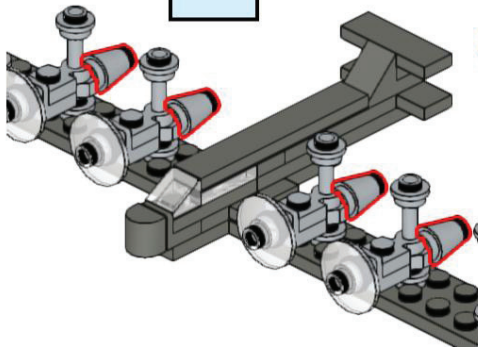

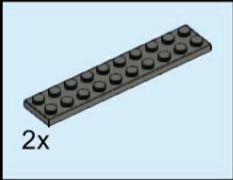
20  2x

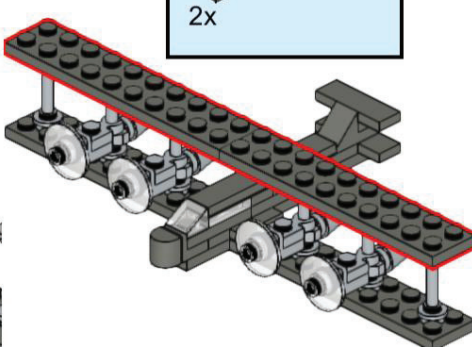

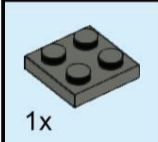
21  1x

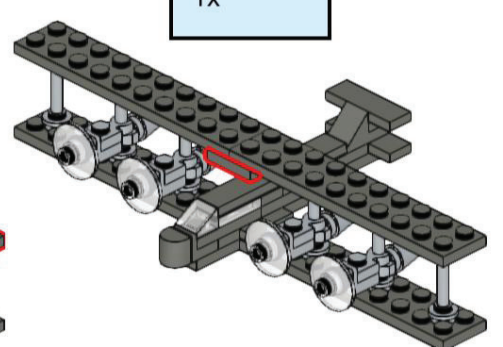

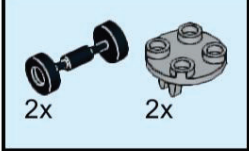
22  2x 2x

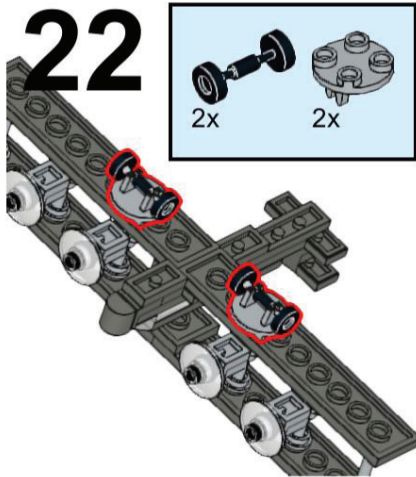

De Zeppelin Staaken IV was een Duitse strategische bommenwerper met vier motoren, in dienst bij de Luftstreitkräfte tijdens de Eerste Wereldoorlog en het enige Riesenflugzeug ("reuzenvliegtuig") dat in een dergelijke hoeveelheid geproduceerd is.

Graaf Ferdinand von Zeppelin, de geestelijke vader van de zeppelin, was een groot voorstander van Riesenflugzeuge. Deze enorme vliegtuigen met veel capaciteit moesten een grote rol spelen in de oorlog.

- Lengte: 22,1 m
- Topsnelheid: 135 km/h
- Bereik: 800 km
- Spanwijdte: 42,2 m
- Gewicht: 7921 kg
- Motortype: 4 x Mercedes D.IVa 6-cilinder met elk 245 pk

